



# installation and user instructions

All instructions must be handed to user for safekeeping

Revision A - 06/09

Country(s) of destination - GB/IE



**eko 3021**  
**eko 3031**

**fan-flue fuel effect gas fire**

# INSTALLATION INSTRUCTIONS



Eko 3021



Eko 3031

## Preliminary Notes Before Installation

This appliance is an Inset Live Fuel Effect appliance which provides radiant warmth utilising the latest type burner technology.

The fire is designed to suit various types of fireplaces and installation methods as detailed in this manual.

The appliance must be installed by a competent<sup>[1]</sup> person in accordance with Gas Safety (Installation and Use) Regulations 1998. Read all these instructions before commencing installation.

This appliance must be installed in accordance with the rules in force and used only in a sufficiently ventilated space.

The appliance is designed for installation on to a non-combustible hearth of at least 300mm depth.

This appliance is factory set for operation on the gas type, and at the pressure stated on the appliance data plate.

This appliance is available with a number of fuel effect options. These instructions cover all fuel effect options. See the relevant sections of these instructions for further details.

Please note : Except where otherwise stated, all rights, including copyright in the text, images and layout of this booklet is owned by Focal Point Fires plc. You are not permitted to copy or adapt any of the content without the prior written permission of Focal Point Fires plc.

[1] GB - Gas Safe™ registered operatives (Northern Ireland only- CORGI registered operatives) are the only class of person considered as competent by the HSE under the Gas Safety (Installation and Use) Regulations 1998.

Section	Contents	Page No.	Section	Contents	Page No.
1.0	Important Notes	1	8.8	Fitting Fan Terminal	11
2.0	Appliance Data	2	9.0	Fuel Bed Layout (Eko 3021 coal)	13
3.0	Installation Requirements	2	9.1	Fuel Bed Layout (Eko 3031 coal)	14
4.0	Terminal Location	3	9.2	Fuel Bed Layout (Eko 3031 pebble)	15
5.0	Site Requirements	4	9.3	Fitting the frame and front	16
6.0	Ventilation	5	10.0	Testing & Commissioning	17
7.0	Unpacking the Appliance	5	11.0	Operating the Appliance	17
7.1	Component Checklist	5	11.1	Spark Failure	17
8.0	Preparing for Installation	5	11.2	Setting Pressure	17
8.1	Outer Wall Aperture	6	11.3	Spillage Monitoring System	18
8.2	Gas Supply Routing	6	11.4	Testing for Spillage	18
8.3	Installation Method 1	7	12.0	Briefing the Customer	18
8.4	Installation Method 2	8	13.0	Servicing	18
8.5	Installation Method 3	9	13.1	Cleaning the Ceramics	19
8.6	Flue Preparation	11	13.2	Dismantling the Burner Tray	19
8.7	Firebox and Tray	11	13.3	Checking the Fan Assembly	19
			13.4	Control Box Removal	20
			14.0	Troubleshooting Guide	20

## 1.0 IMPORTANT NOTES

This fire is an Inset Live Fuel Effect Gas Fire providing radiant warmth. It is designed to operate on Natural Gas only.

It is the LAW that all gas appliances and fittings are installed by a registered competent<sup>[1]</sup> person and in accordance with the Gas Safety (Installation and Use) Regulations 1998, the relevant British Standards for Installation, Codes of Practice and in accordance with the Manufacturers' Instructions. The installation shall also be carried out in accordance with the following regulations:

The Building Regulations issued by the Department of the Environment, the Building Standards (Scotland) (Consolidation) Regulations issued by the Scottish Development Department.

BS 5871 part 2

BS 5440 part 1

BS 6891

BS 6461 parts 1 and 2

BS 3456 part 201

BS-EN 60335

**Note - For Republic of Ireland, reference should be made to the relevant standards governing installation, particularly in regard to flue sizing and ventilation. See IS813, ICP3, IS327 and any other rules in force.**

**Failure to comply with these regulations could lead to prosecution and deem the warranty invalid.**

**Consult all instructions before installation and use of this appliance.**

**This appliance is free from any asbestos material. Refractories and coal bed are constructed from ceramic fibre.**

[1] GB - Gas Safe™ registered operatives (Northern Ireland only- CORGI registered operatives) are the only class of person considered as competent by the HSE under the Gas Safety (Installation and Use) Regulations 1998.

## 2.0

### APPLIANCE DATA

	<u>Eko 3021 models</u>	<u>Eko 3031 models</u>
Gas Group	G20 Natural Gas CAT I2H	G20 Natural Gas CAT I2H
Inlet Pressure	20 mbar	20 mbar
Max Energy Input (gross)	6.2 kW	6.8 kW
Min Energy Input (gross)	3.5 kW	3.5 kW
Pilot Energy Input (gross)	166 W	166 W
Setting Pressure	15.2 mbar (+/- 0.75mbar)	15.8 mbar (+/- 0.75mbar)
Main Injector Burner	Stereo size 78	Stereo size 81
Gas Inlet Connection	8mm compression	8mm compression
Ignition	Piezo spark	Piezo spark
Gas Valve	BM733/NGC6802	BM733/NGC6802
Spark Gap	3.5 to 4.5mm	3.5 to 4.5mm
Electrical Supply	230V~50Hz (ac)	230V~50Hz (ac)
Current Rating	0.3A running, 0.4A on start up	0.3A running, 0.4A on start up
Fuse Rating	3 Amp	3 Amp
Approximate Weight	Fire Unit 20Kg, Fan Unit 12Kg	Fire Unit 20Kg, Fan Unit 12Kg
Flue Specification	Twin walled circular section flue tube provided with appliance. No additional or alternative flue may be used. Outer flue tube diameter 120mm	

See Data Badge affixed to appliance for current data.

**This appliance is for use only with the gas type, and at the pressure stated on the appliance Data Badge, and is for decorative purposes.**

## 3.0

### INSTALLATION REQUIREMENTS

Compatible wall thicknesses for the Installation Methods detailed in this Guide are as follows;

* These dimensions allow for 25mm Rockwool insulation jacket, other forms of insulation may require adjustment.	<b>Eko 3021</b> Min	<b>Eko 3021</b> Max	<b>Eko 3031</b> Min	<b>Eko 3031</b> Max
Surface mounted firebox/surface mounted fan terminal.	75mm	570mm	60mm	560mm
Surface mounted firebox/recessed fan terminal.*	160mm	660mm	150mm	650mm
Recessed firebox/surface mounted fan terminal.	220mm	720mm	265mm	765mm
Recessed firebox/recessed fan terminal.	310mm	810mm	355mm	855mm

Note: These dimensions are between the surface of the marble/backpanel and the surface of the outside wall.

#### Internal

This appliance MUST NOT be installed into a room containing a bath or shower, or where steam may be present. The firebox must be installed onto a suitable non-combustible insulating surface at least 12mm thick, covering the entire base area of the box. This appliance is suitable for use with a "lightweight" surround and back panel of 150°C minimum rating. A suitable gas supply and an electrical 3 Amp fixed fused spur are both required near the intended appliance site.

#### External

Please refer to the diagram on the following page for more details of the most suitable site for the fan terminal. The terminal must be located so that the outlet is not obstructed in any way allowing poor disposal of combustion products. A safety cage should be fitted in place over the terminal to ensure compliance with Byelaws. Terminals located in passageways between two properties, public footpaths or which might discharge over the same may be subject to local byelaws on items such as minimum distances for projection. In these circumstances it is the installers responsibility to check that the location of the terminal does not infringe any byelaws. If in any doubt about flue terminal location, especially with regards to garages and car ports then further advice should be sought from CORGI or the manufacturer.

### 3.0 INSTALLATION REQUIREMENTS (continued)

Avoid locating the terminal in close proximity to combustible materials, such as plastic drainpipes and fences. If these are impossible to avoid, then a suitable metal deflector must be used if the flue gasses begin to heat the object. For minimum standard dimensions of clearance see below.

Covered areas such as under car ports should be avoided but if no alternative is available the following notes should be adhered to; The covered area should have at least two open sides (i.e. a roof and ONE supporting wall). If more than one side is filled, then advice must be sought on the location's suitability. Any openings into dwellings such as doors, windows and air vents under the covered area must be at least 1200mm away from the terminal position. If the roof is constructed from plastic material, great care must be taken with the installation as there is no simple method of protecting this type of roof from heat build up.

### 4.0 TERMINAL LOCATION

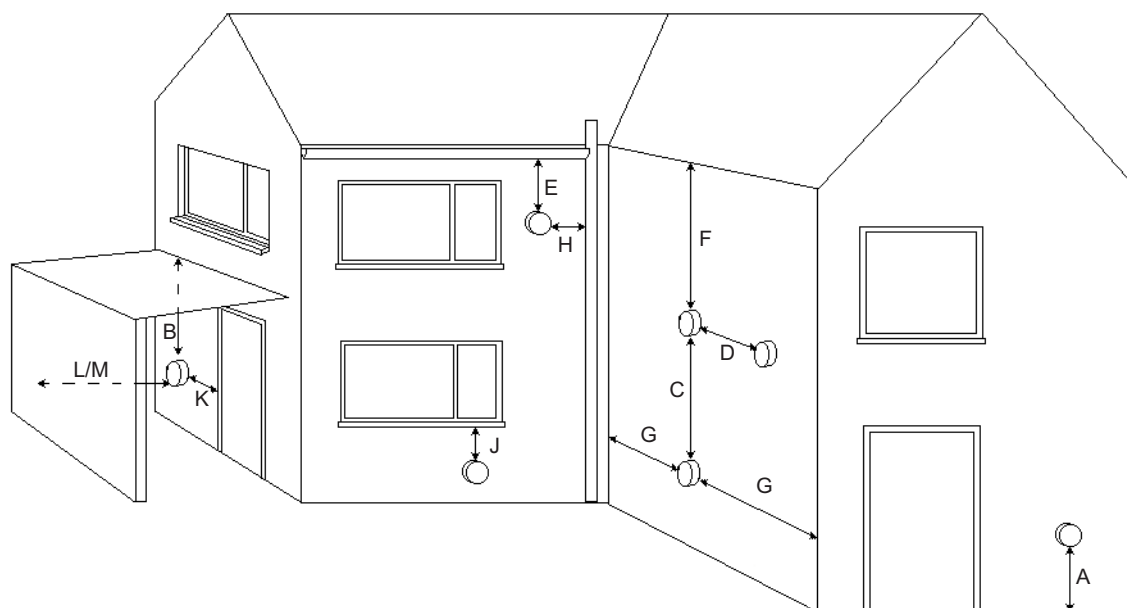

#### Minimum location distances

- A - 300mm above ground level/roof or balcony level.
- B - 200mm below balconies or car ports.
- C - 1500mm vertically between terminals.
- D - 300mm horizontally between terminals on same wall.
- E - 75mm below gutters, soil pipes or drain pipes.
- F - 200mm below eaves.
- G - 300mm from internal or external corners
- H - 150mm from vertical drain pipes.
- J - 300mm directly below an openable window or other opening e.g. air vent.
- K - 1200mm from an opening into the building under a car port.
- L - 600mm from a surface facing the terminal.
- M - 1200mm from another terminal facing the terminal.

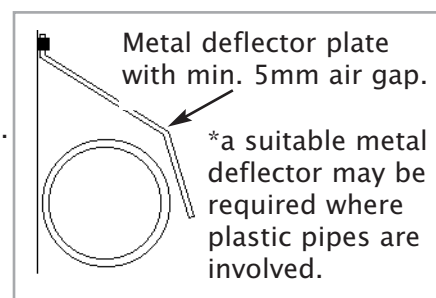

Care should also be taken with the terminal location relative to nearby plants, grass, or trees as the gases expelled may be hot enough to damage them. At least 1000mm clearance is recommended.

**Note: Dimensions relate specifically to the exhaust outlet at the base of fan terminal box.**

## 5.0 SITE REQUIREMENTS

For aesthetic purposes it is essential that the hearth and infill plinth area are flat and level. The hearth and infill must also be square to the back panel. Failure to comply with this could cause the appliance to lean away from the fireplace resulting in an unsatisfactory installation.

The electrical earth to the property and all wiring must be carried out in accordance with IEE Wiring Regulations (including any Local Regulations). If you are unsure about this aspect, then professional advice should be sought. This appliance is suitable for use with a 230V~50Hz (ac) single phase (normal domestic) electrical supply. Connection to the mains supply should be made with the three core cable (green/yellow -earth, blue - neutral, brown - live) to a fixed fused spur with double pole insulation (minimum 3mm separation of poles) and fused at 3 amp. Take care not to pull or damage the internal wiring to the fan unit at any time during installation. Should the mains cable become damaged at any stage, it should only be replaced with the manufacturer's supplied cable (part no. EL006225/0). Failure to use a genuine spare could cause a hazard.

### **WARNING! THIS APPLIANCE MUST BE EARTHED.**

If a concealed gas supply is to be used, the supply pipe must be sleeved through walls and floors. If the fire is to be inset into the cavity leaf, only factory sleeved pipe should be used. For further details see relevant section. A separate isolation device must be incorporated into the incoming gas supply to facilitate servicing. No more than 1.5 metres of 8mm pipe should be used in the connection of the gas supply to the appliance, as more could result in an unacceptable drop in pressure.

This appliance must only be installed onto a non-combustible wall or surface. The fire requires a hearth with a non-combustible surface at least 12mm thick. The top surface of the hearth must be at least 50mm above floor level, or be surrounded by a raised edge or fixed fender of at least 50mm high. The non-combustible hearth must extend a minimum of 300mm in front of, and 150mm either side of the live part of the appliance. The hearth must therefore be a minimum of 680mm wide.

The appliance must be installed by one of the following methods;

- 1 - Fitment against an existing inner house wall with a suitably constructed fireplace and/or false chimney breast to enclose the depth of the fire.
- 2 - Insertion into a purpose made opening in the inner leaf of a cavity wall or disused fireplace opening with the use of a suitable fireplace surround etc. **Note: The appliance must not bridge the cavity - any overhang being kept to a minimum, and the installation instructions must be adhered to. Building Control requirements may vary in some areas, enquiries should be made accordingly.**
- 3 - Installation into a timber framed dwelling using the clearances to combustible materials shown in the relevant section. Building Control requirements vary in some areas, enquiries should be made accordingly.

An unprotected combustible shelf may be fitted above the appliance, provided it complies with the minimum dimensions stated below. Protective materials can be used to deflect heat from shelves that are too low.

Maximum depth of shelf	Minimum distance from finished hearth surface to underside of shelf
100mm (4in)	745mm (29 1/4 in)
150mm (6in)	845mm (33 1/4 in)
203mm (8in)	895mm (35 1/4 in)

A non-combustible shelf may be fitted to within 10mm of the top edge of the fireframe. Combustible materials, such as wood, may be fitted to within 100mm (4in) of either side of the frame of the firebox providing it projects no further forward than 100mm (4in). As with all heating appliances, decorations, soft furnishings and wall coverings (such as blown vinyl, flock and embossed paper) may discolour or scorch if positioned too close to the fire. If the appliance is fitted to a dry-lined wall, the gap between the plasterboard and blocks must be sealed with non-combustible material and any unplastered board replaced with superlux or other non-combustible material if in direct contact with the appliance.

## 6.0 VENTILATION

No purpose provided ventilation is normally required with this appliance. However, the ventilation requirements of other gas appliances in the same room or space should be taken into consideration. A spillage test should be carried out as described in the relevant section with the doors and windows both open and closed, and with any extractor fan running on full. Where fitted, ventilation must comply with the requirements of BS 5440 part 2. Vents directly underneath or within the immediate vicinity of appliances **must not** be used as they may adversely affect ODS pilot operation.

**Note: For Republic of Ireland see IS813, ICP3 and IS327 and any other rules in force.**

## 7.0 UNPACKING THE APPLIANCE

Stand the carton right way up, cut the strapping bands and remove the top end cap. Read all the instructions before continuing to unpack or install this appliance.

Remove the box containing the fire front, and the bag containing the ceramics. Remove the cardboard packing pieces, and any bags containing other fittings or parts. When all loose parts have been removed, the outer sleeve may be lifted off to reveal the appliance.

Check that the components supplied correlate with the checklist given in section 7.1.

Please dispose of the packaging materials at your local recycling centre.

## 7.1 COMPONENT CHECKLIST

QUANTITY	DESCRIPTION	QUANTITY	DESCRIPTION
1	Firebox and burner tray assembly	1	Fan assembly
1	Decorative fireframe	1	Twin-walled tubular flue
1	Fire front with separate ashpan cover	1	Rockwool jacket
1	Moulded ceramic fibre combustion matrix	1	Terminal guard cage
1	Front coal piece (Eko 3031 models)	1	Fan box cover
1	Bag of 11 moulded coals (Eko 3021 coal models)	1	Fan box trim
1	Bag of 16 moulded ceramic coals (Eko 3031 coal versions)		
1	Bag of 16 ceramic pebbles (Eko 3031 pebble versions)		
1	Set of manufacturers instructions		
1	Bag of fixings (10 rawl plugs, 10 No8x1.5 screws, 4 No8x0.5 screws), 3 lengths of sealing strip		
1	Rear ceramic panel		
2	Ceramic side panels (Eko 3031 models)		

## 8.0 PREPARING FOR INSTALLATION

Remove the fire tray from the firebox by removing the two securing screws in the front legs of the tray and rear mounted transit screws, and invert the tray. Carefully unplug the safety solenoid on the tray from the control box by squeezing the clip on the three way connector and easing apart. Place the tray safely to one side along with the fuel bed components, firefront and decorative frame.

The three radiant panels may now be fitted inside the firebox. Select the plain or patterned side of the panels and insert as follows; Lay the firebox on it's back. Lay the tapered panel onto the rear face of the firebox. The side panels should be fitted by inserting their front edges into the pre-fitted retaining brackets on the front face of the firebox. Gently align the side panels with the sides of the firebox, over the back panel already in place. Make sure that the side panels are pushed **up** firmly to the roof of the firebox, and **back** firmly to retain the rear panel. Make small adjustments to line up the mortar lines if required. Clamp the side panel using the 'L' shaped brackets and screws provided. The screws should locate into the holes in the sides of the firebox.



## 8.0 PREPARING FOR INSTALLATION (continued)

Apply the self adhesive sealing strip to the rear perimeter of the firebox frame so as not to be visible. This will eventually seal the firebox to the fireplace back panel. Place the fire to one side whilst the site is prepared for flue installation. Mark the vertical centreline of the desired location of the appliance after first checking for clearances to pipes and cables in the wall, and also the terminal position outside.

**Note: The vertical centreline of the pilot hole will either be 475 (Eko 3021 models) or 500mm (Eko 3031 models) from the floor PLUS the thickness of the hearth you are using. This dimension is obviously FROM the hearth top surface if it is already fitted**

Mark the position of the 30mm cable hole in relation to the flue centreline. Using a suitably long masonry bit, drill through both leaves of the cavity wall. Check outside that the clearances from the hole are adequate for installation to proceed. Check all dimensions with the diagram in the relevant section. Now drill the 30mm cable hole in the wall.

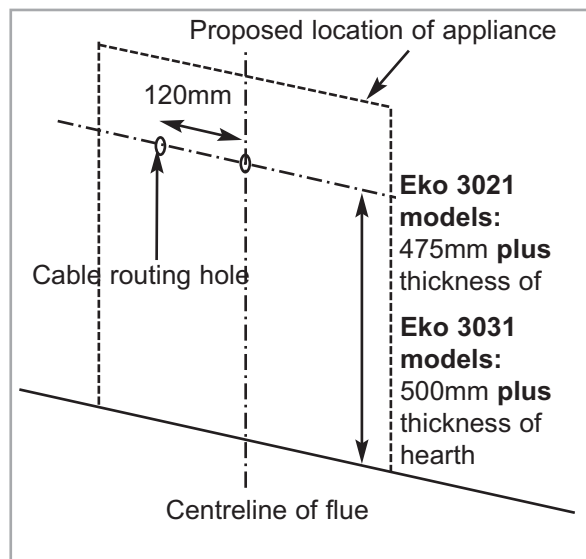

## 8.1 OUTER WALL APERTURE

From the outside of the property, open up the pilot hole in the external leaf of the cavity to the required size.

If the fan terminal is to be mounted directly onto the outside wall, the hole should be opened up to a 125mm diameter aperture centred around the pilot hole.

If the fan terminal is to be recessed into the outer leaf, the hole should be opened up to the dimensions given in the diagram.

Clear all the brick rubble and debris that may have fallen into the cavity. If the cavity wall insulation is obstructing your view of the inner leaf then clear this back.

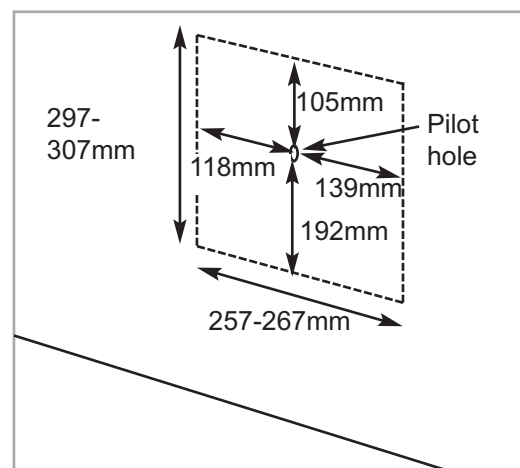

## 8.2 GAS SUPPLY ROUTES

The gas supply may enter the appliance across the hearth or through the 'knock outs' provided in the rear of the firebox. Gas pipes should not be buried or routed through walls without being protected by conduit or sleeving. An isolation tap must be included in the gas connection pipe to facilitate servicing.

**Note: Any fittings used underneath the appliance must be rated to 80°C and must not come into contact with the underside of the burner unit**

For INSTALLATION METHOD 1, the gas supply can be run in the conventional manner taking due account of rules and regulations.

For INSTALLATION METHOD 2, use only factory sleeved pipe in a continuous unjoined length in the cavity of the wall and area which communicate with the cavity. Ensure a good seal where the pipe enters through the appliance grommet. This is a permitted gas supply routing.

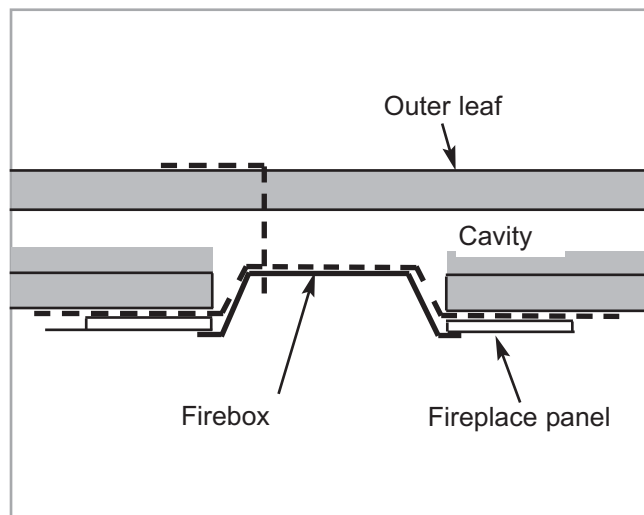

## 8.3 INSTALLATION METHOD 1

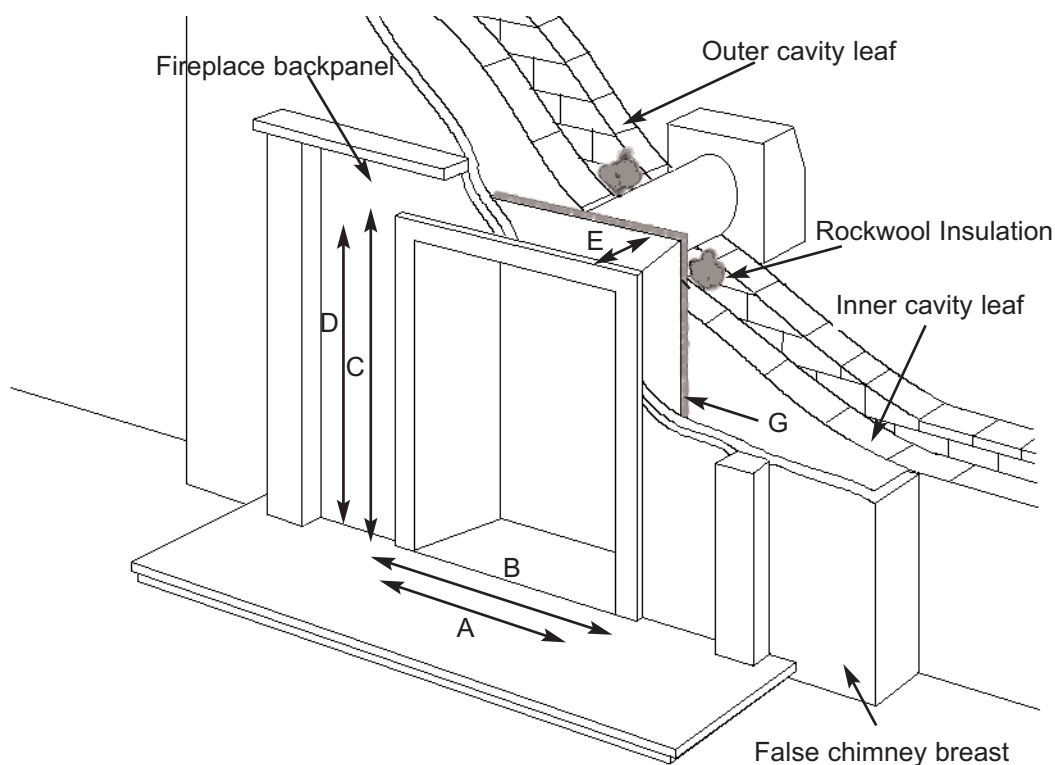

- A- Opening width: (Eko 3021 380mm min 450mm max) (Eko 3031 375mm min. 460mm max.)
- B- Overall width: (Eko 3021 and Eko 3031 480mm)
- C- Overall height (excluding hearth): (Eko 3021 and Eko 3031 590mm.)
- D- Opening height: (excluding hearth): (Eko 3021 and Eko 3031 565mm min. 580mm max.)
- E- Recessed depth of fire: (Eko 3021 125mm) (Eko 3031 180mm)
- F- The hearth must extend 300mm in front of the appliance, with it's top surface 50mm above the surrounding floor level or having a 50mm high fixed fender around it's perimeter.
- G- Space allowed for Rockwool jacket: 25mm

**This method requires minimal modification to the property's wall and is achieved utilising either an extended firesurround or by constructing a shallow false chimney breast of a minimum 180mm deep. See diagram for further dimensions.**

Centering on the pilot hole already drilled, create a hole from inside the property 125mm diameter. If the property has loose fill cavity wall insulation fitted, it will be necessary to seal the wall cavity where the flue opening is formed to prevent insulation material coming into contact with hot surfaces of the fire and it's components. The recommended method is to pack a depth of 50-100mm of Rockwool or a similar non-combustible insulation material into the cavity .

Where the property does not have existing cavity wall insulation, it is still recommended that a space 50-100mm into the cavity is packed with Rockwool or similar material, to prevent any future installation of cavity wall insulation from coming into contact with hot areas of the appliance.

At this point the false chimney breast or fire surround should be installed.

**Note: When constructing the stud partition, all uninsulated, combustible material must be kept a minimum of 75mm away from the fireplace. Combustible materials closer than 75mm MUST be protected with a minimum of 25mm insulation material.**

## 8.4 INSTALLATION METHOD 2

This method allows for installation of the appliance with the rear part of its firebox recessed into the inner leaf of the cavity wall. This will enable a standard fireplace to be flush fitted to the wall and the appliance will then be fitted flush into the fireplace. The structural integrity of the wall must be maintained.

Check on the type of cavity insulation used, and if it is of the granular type then take suitable precautions when opening up the wall not to allow excessive loss of insulation material from the cavity. Packing the cavity with Rockwool should help hold back loose fill insulation material. Unless lime and mortar has been used, it will be necessary to drill four holes with a masonry drill, and then use a mechanical cutter (Sharksaw) to cut out the correct size of 'slot' required for the chosen lintel.

**NOTE:** Obtain a lintel 750mm long x 75mm deep x thickness of the inner leaf. We would suggest either a pre-cast concrete or steel lintel; Catnic CN52 or CN46 depending on thickness. Typical inner leaf weights when sizing a lintel over a 450mm wide opening are 90kg for 100mm blockwork and 120kg for 125mm blockwork.

Plan to minimise disruption to occupants and protect any other parts of the building against dust infiltration. Areas that are opened up will need to be protected against rain or snow during the work and if there is a risk of frost, replacement brickwork will require protection until mortars have hardened.

Set out where possible centrally beneath a block join as shown. Use a drill for guide holes, and a 'shark saw' or angle grinder to form an opening to suit the lintel.

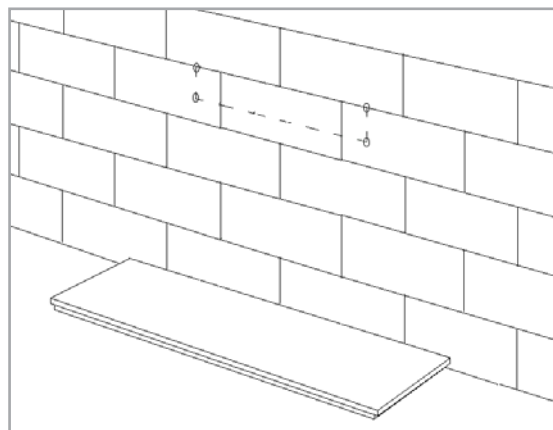
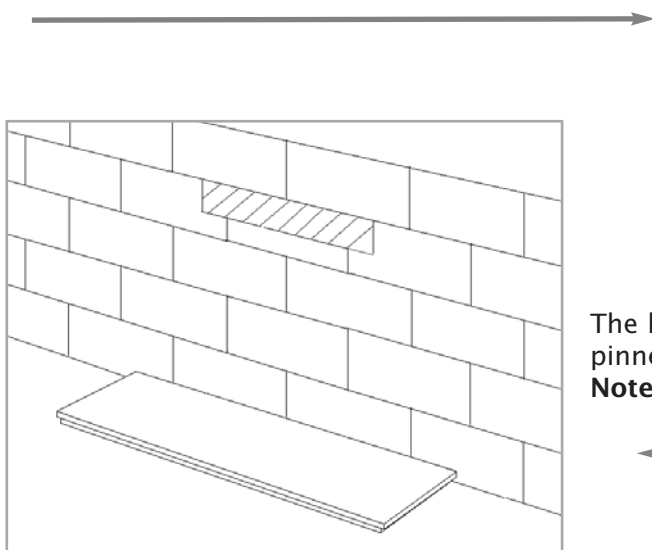

The lintel should be inserted and securely slate pinned, leaving the wall above safe and firm.  
**Note: Always bed on mortar, DO NOT dry bed.**

Remove all masonry from below the lintel, and clear debris from the cavity. The top of the exposed cavity must be sealed with Superlux board or a similar non-combustible material. The board should be fixed at an angle, lower at the back, so as to direct any moisture coming down to the outside wall. This board should be fixed with screws, Unibond, or a similar adhesive. It is important to fit this board or a cavity tray to protect the property and the appliance from drips of water. The sides of the opening where the cavity is exposed should be packed with Rockwool or similar non-combustible material to a minimum depth of 50mm. The Rockwool packing must extend from the base of the opening to the Superlux board. The non-combustible hearth should now be formed or secured in place.

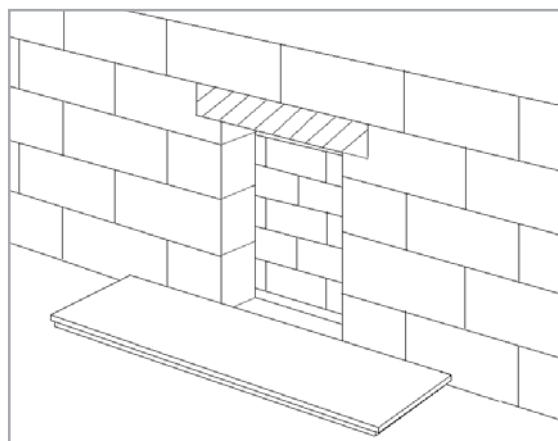

## 8.4 INSTALLATION METHOD 2 (continued)

It is essential the Rockwool pad be fitted to the rear of the appliance to prevent condensation and to insulate the appliance firebox from the cold air of the cavity.

**Note: Neither the appliance nor the Rockwool insulating pad should bridge the cavity. Consult your local Building Control Department for any additional construction requirements or further advice.**

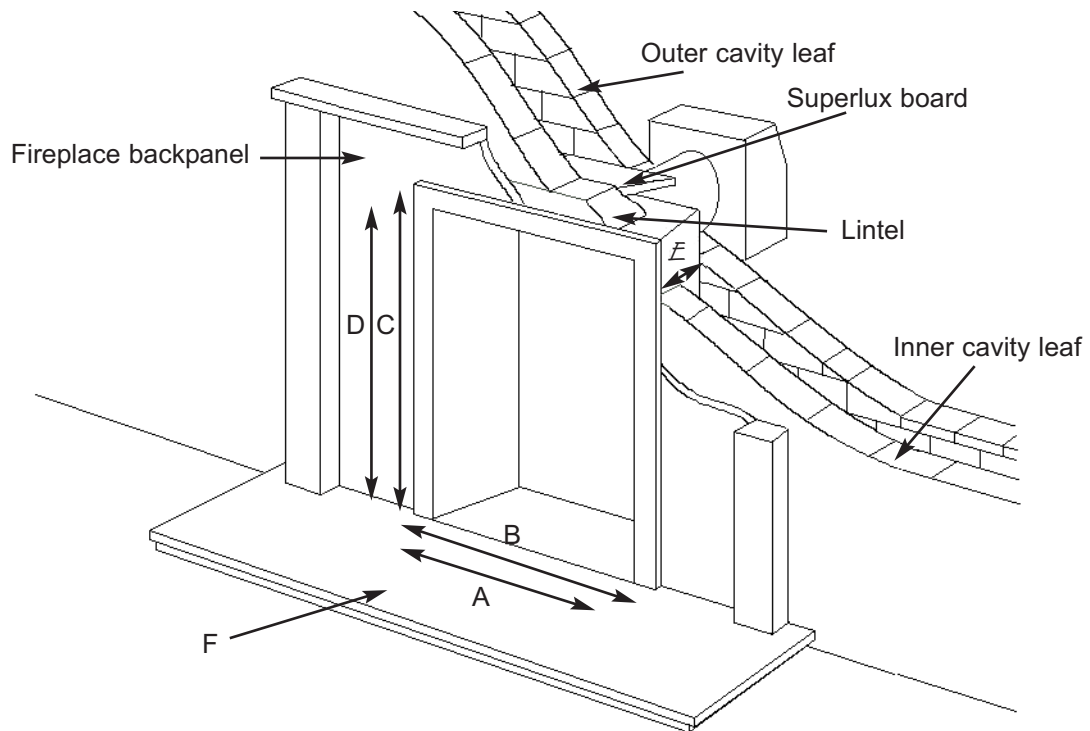

- A- Opening width: (Eko 3021 380mm min 450mm max) (Eko 3031 375mm min. 460mm max).
- B- Overall width: (Eko 3021 and Eko 3031 480mm)
- C- Overall height (exc hearth): (Eko 3021 and Eko 3031 590mm)
- D- Opening height: (exc hearth): (Eko 3021 540mm min 580mm max) (Eko 3031 565mm min. 580mm max)
- E- Recessed depth of fire: (Eko 3021 125mm) (Eko 3031 180mm)
- F- The hearth must extend 300mm in front of the appliance, with it's top surface 50mm above the surrounding floor level or having a 50mm high fixed fender around it's perimeter.

## 8.5 INSTALLATION METHOD 3

### Installation into timber framed dwellings

Where removal of any part of the inner timber leaf of the wall is involved, the structural integrity of the wall must be maintained and the advice of your local Building Control Department should be sought. If the property is under any N.H.B.C. cover, it is advised that their advice on this modification should also be sought.

Either of the two preceding methods of installation may be adapted for use in timber framed buildings, providing extra care is taken to prevent combustible materials from contact with hot surfaces. The appliance must be installed in accordance with British Gas documents DM2 and DM3 or the Institute of Gas Engineers published procedure IGE/UP/7.

Special attention must be paid to the location of the studwork frames of the inner leaf and the appliance positioned accordingly. Wires and pipes that run within the inner timber leaf must also be located and taken into account when positioning the appliance.

## 8.5

### INSTALLATION METHOD 3 (continued)

#### Installation using rebated fire surround or false chimney breast.

When using this method of installation the following amendments should be incorporated 25mm clearance must be allowed from the appliance firebox to any insulated combustibles. 75mm clearance must be allowed to any unprotected combustibles. 50mm minimum thickness of insulation should be provided around flue pipe and gather hood. Where the flue pipe passes through the inner leaf, a hole 100mm larger than the flue should be cut to allow 50mm air gap around the entire flue circumference.

The vapour barrier on the back of the inner leaf should be cut and carefully fixed to prevent any ingress of damp into the plasterboard layer. A layer of insulation will need to be provided to insulate the surface of the inner wall from the heat effect of the flue. It may be advantageous to use a sheet of Superlux board for this purpose.

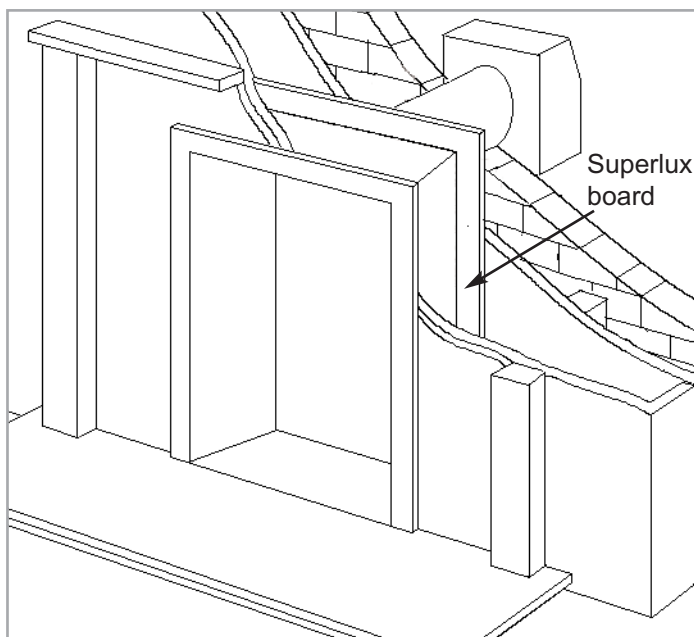

#### Installation by setting the appliance into the inner leaf of wall.

When setting the appliance into the inner wall find a suitable position between the wall panel frames and carefully open up a hole to the dimensions given in the relevant section, paying careful attention to securing the damp proof membrane back into position. A drip collar of galvanised or stainless steel should be formed with the twisted joint on the underside of the flue to disperse drips.

An air gap of 75mm between all hot surfaces and the surrounding wall should be allowed, if protective insulation is used this may be reduced to 25mm clearance. The exposed cavity should be sealed off using Superlux or a similar non-combustible board, see below.

**Note: Neither the appliance nor the Rockwool insulation should overhang the cavity space.**

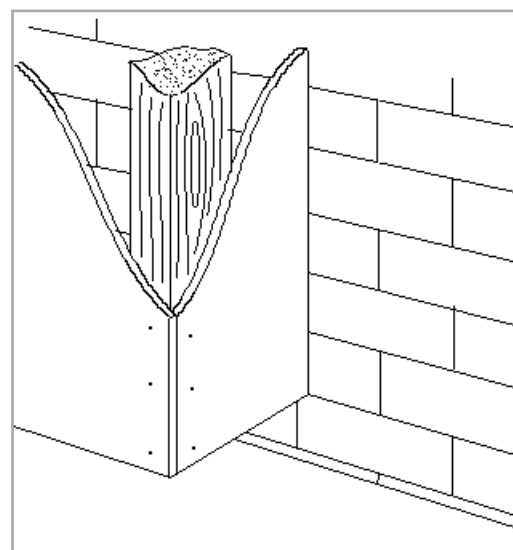
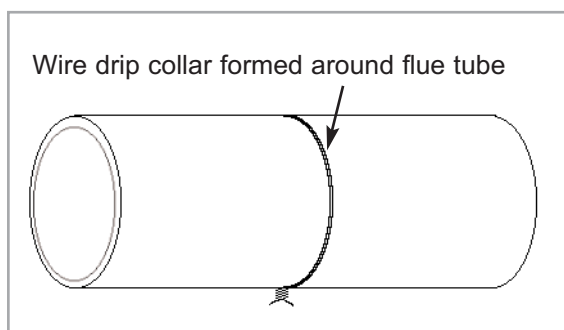

## 8.6 FLUE PREPARATION

When all the preparation work has been completed for whichever method of installation has been chosen, and with the fire surround fitted, take the appliance and slide the round flue section over the spigot on the rear of the fire. Protect any decorative hearth with a dust sheet or similar, place the appliance in position with the flue section protruding through the wall(s) to the outside. Make sure the firebox is fully pushed home before marking two fixing holes in the base of the firebox. Outside the property, mark a line on the flue tube level with the outer surface of the wall, where it protrudes through.

Remove the firebox from the location and slide off the flue section. If the fan terminal is to be mounted directly on the outside wall, cut the flue tube to length along the marked line. **If the terminal is to be recessed into the outer wall, a second line should be marked 85mm back towards the appliance.** The flue tube should then carefully be cut to length along the relevant line. Do not remove the ceramic insulation. File off any rough edges and slide back on to the appliance spigot ensuring the 'O' ring remains seated in its channel. Slide the Rockwool jacket into place over the flue section, this may be secured with aluminium tape. With a suitable drill bit, make the two previously marked holes in the base of the firebox, drilling down through into the non-combustible hearth. Fit two rawl plugs into the holes.

## 8.7 FIREBOX AND BURNER TRAY

The mains electrical supply cable exits from the rear of the appliance and the FIXED FUSED SPUR (fused at 3 Amp) should be arranged to allow easy connection.

Stand the appliance in front of the opening and feed the fan wiring harness through the hole drilled in the wall. You may find this easier if a short length of plastic conduit is first fitted to the hole. The cable must run outside of the insulating jacket, and be arranged so that it does not touch any hot surfaces. Feed the mains cable through to the location of the fixed fused spur. Depending on the location of the 8mm gas supply, feed through the back of the firebox and fit the grommet seal (if applicable). Now carefully slide the appliance back into position and secure into place using the two previously drilled holes. Ensure the flue unit has passed correctly through the wall.

**Note: If using an over hearth gas supply, the route of the pipe should be located through the purpose provided cutouts (if applicable) on the decorative firefront supplied with the appliance.**

Place the burner tray near to the firebox and connect the three-way plug from the control box to the safety solenoid mounted on the burner. Connect the gas supply to the entry point on the gas valve. Secure the burner tray into position with the two screws through the burner legs.

## 8.8 FITTING THE FAN TERMINAL

The external fan terminal can now be fitted. This comprises three parts, the wall fan box section, the cover and the trim frame (only used for recessed mounting). At this point, the trim must be fitted to the fan box unit if the terminal is to be recessed into the wall. Remove the four self tapping screws from the sides of the fan box, and slide the trim frame over the box with the fixing flanges facing into the wall. Secure with the four screws and proceed to fit the terminal as described below.

Offer up the fan unit and feed the connecting cable through the entry hole in the wall plate. It may be advantageous to remove the rubber grommet in the entry hole to aid insertion of the wires and refit afterwards. Run the connectors through the entry hole, then feed them through the grommet, before finally refitting the grommet to the entry hole.

**Note: The grommet MUST be refitted in order to prevent damage to the fan wiring harness.**

### **Installing the fan terminal by surface mounting on the outside wall**

Slide the fan unit on to the previously installed flue pipe. Mark the four fixing screw positions on the wall, and drill the 5mm securing holes into the brickwork. Affix the fan terminal to the wall with the rawl plugs and screws provided. A bead of silicone weather sealant, or similar suitable sealant should be applied along the top edge, and down the two sides of the terminal where it meets the wall, to prevent the ingress of water. Any excess sealant should be wiped away.

## 8.8 FITTING THE FAN TERMINAL (continued)

### Fitting the fan terminal by recessing into the outer wall

If already fitted, remove the four long M4 screws from the top and bottom of the fan terminal. Fit the terminal into the wall opening previously prepared, ensuring the flue tube seats correctly over the terminal spigot. When correctly fitted, insert the four screws into the threaded inserts fitted to the inside of the top and bottom of the terminal. Using a suitable screwdriver, continue to wind in the four screws from the inside of the box until the fan terminal is held securely in the opening. Alternatively, four holes may be marked in the sides of the fan terminal, and these drilled through into the brick work. The terminal can then be secured with wall plugs and screws. Apply a bead of silicone weather sealant, or similar suitable sealant around the top and side edges of the frame to provide a good seal to the wall, eliminating water ingress.

**Note: The recessed fan terminal MUST NOT be cemented into place within the outer wall. The louvres in the sides of the fan terminal MUST be allowed to vent to the cavity to aid cooling of components within.**

With the terminal fixed into position the wires may now be connected. Attach the green earth wire to the screw securing the fan earth wire. Fit the two three way connector to the relevant connectors from the fan unit and pressure switch. Check that none of the wires can come into contact with hot surfaces or moving parts of the fan. Use the cable tie supplied to secure the wires to the terminal. With all the cables properly connected, fit the terminal cover ensuring the fan outlet is clear, and secure with the four screws provided. Offer the wire terminal guard cage into position, mark and drill the relevant mounting holes, and secure into place using rawl plugs and screws. The terminal guard should be fitted at all times to comply with any byelaws in force.

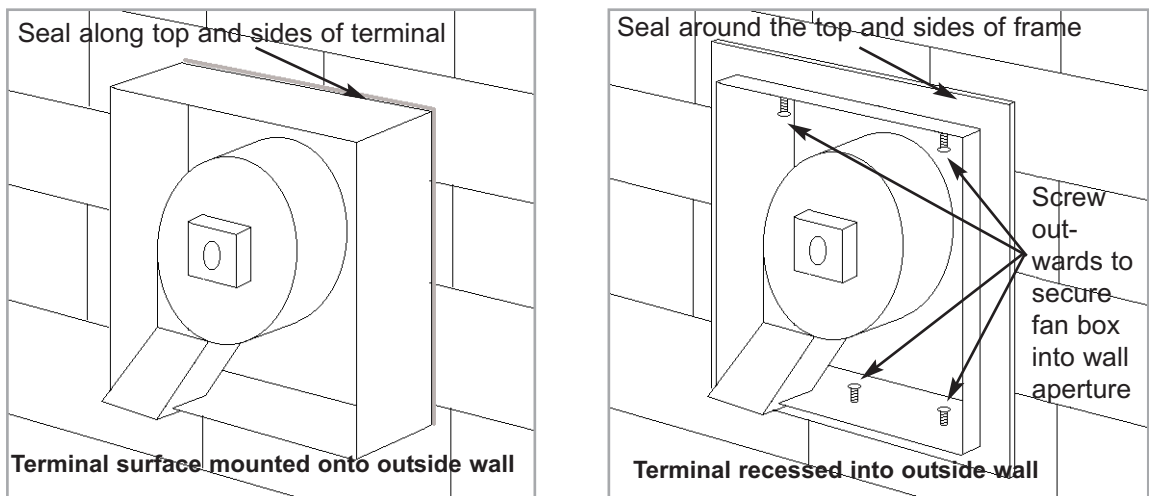

### Schematic wiring of fan unit

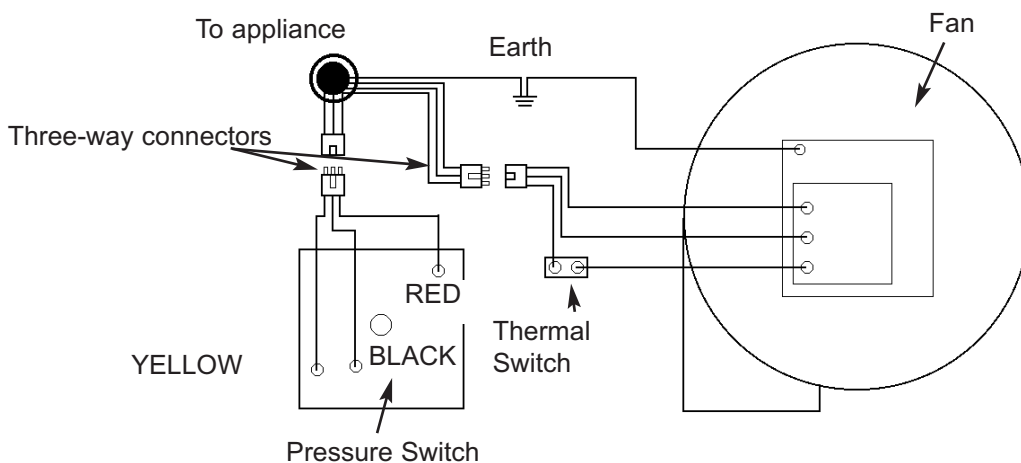

## 8.9 GAS CONNECTION

Refit the burner tray into the firebox, fit the two screws through the locating holes in the tray legs, and tighten.

Purge the gas supply thoroughly to remove air and dirt/debris **BEFORE** connection. Now disconnect the inlet restrictor elbow from the inlet pipe. Connect the previously installed gas supply to inlet restrictor elbow, and re-fit the restrictor elbow to the inlet pipe of the appliance.

If the data/control plate is not already fitted, attach with two screws, ensuring the control knob is free to be depressed fully.

## 9.0 FUEL BED LAYOUT – Eko 3021 MODELS

This fire is supplied with 11 ceramic coals. The coals may vary slightly in size, shape, in order to allow a realistic layout.

Firstly, remove the ceramic components from their protective packaging, and place the brick panel against the rear of the firebox

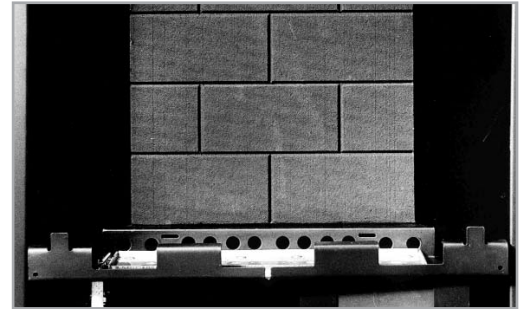

Place the ceramic combustion matrix onto the burner.

Place the front row of five coals on to the matrix. Ensure the coals are firmly against the side cheeks as shown in the photograph. If necessary, pull the coals forward slightly to ensure their rear edges do not overhang the flame ports. The edges of the coals **MUST NOT** be allowed to enter the flame ports.

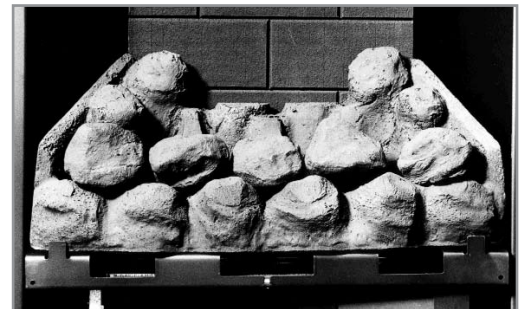

Place the middle row of four coals onto the supports in the matrix, over the top of the holes. Ensure the coals are not turned sideways, such that they actually enter the holes.

Finally, place the rear row of two coals.

**Note:** The coals must not be crammed together, or inserted into the holes in the matrix. A well laid out, generously spaced coal layout will give the best results. The coals may be rotated slightly within their positions to give a good visual effect. Pay special attention to finally adjust the coals with the fire lit on the HIGH setting in order to ensure that no flames play onto the firebox sides. This will reduce the possibility of heat discolouration.

**The fire is designed to operate correctly with the coals supplied when assembled according to the instructions. Never add to the eleven coals, or change them for a different type. Never throw rubbish or other matter onto the fuelbed.**



## 9.1 FUEL BED LAYOUT Eko 3031 MODELS

### Coal Effect Option

1. Remove the combustion matrix from its protective packaging, and position onto the burner tray as shown. The front edge of the matrix should sit snugly behind the back edge of the burner rails. Do not fit the matrix on top of the burner rails.

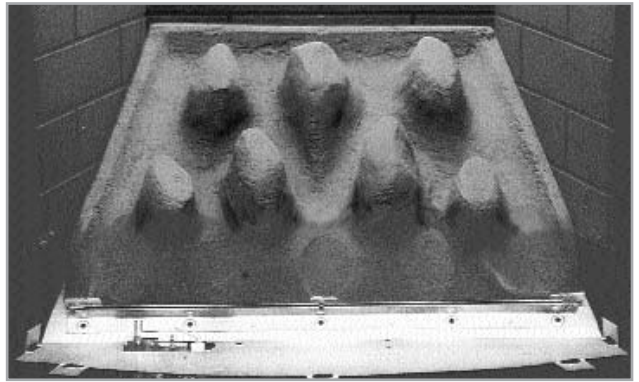

2. Next, remove the front coal strip from its protective packaging and position as shown. The rear edge of the front coal strip should fit in front of the burner rail. Again, do not place on top of the burner rails. When the front coal is in position bend up the three metal tags at the front of the tray to retain (inset).



3. Open the bag of 16 moulded coals. All of the coals are the same. Take five coals and place them as shown. Care should be taken to ensure that the coals bridge the gap between the front coal and the four coal supports at the front of the matrix. Care should also be taken not to push the coals right down between the coal supports, as this can detract from the flame picture when the appliance is running.



4. Take five more moulded coals and position as shown to form the 'second row' of the fuel effect. The coals may be rotated as desired to fit into the gaps between the coal supports in order to create a random, realistic effect. Again, remember not to push the coals down too far into the valleys between the coal supports as this can have a detrimental effect to the flame picture.



## 9.1 FUEL BED LAYOUT - continued Eko 3031 MODELS

### Coal Effect Option

5. Now take another four coals and place behind the second row of coals, in order to complete the third row. The coals may be orientated as desired to achieve a realistic effect. Keep the spacing between the coals even and uniform. The two coals at the ends of the row may be placed rearwards, towards the back corners of the fuel matrix.



6. Finally, take the two remaining coals and place at the back of the fuel matrix, in the centre as shown. Adding these coals should complete the appearance of the fuel bed giving an even distribution of equally spaced coals.



The fire is designed to operate correctly with the coals supplied when assembled according to the instructions. Never add to the sixteen coals, or change them for a different type. Never throw rubbish or other matter onto the coal bed.

## 9.2 FUEL BED LAYOUT - Eko 3031 MODELS

### Pebble Effect Option

1. Refer back to section 9.1 - Fuel bed layout (coal effect option) and follow steps 1 and 2. The front strip and fuel effect matrix used for pebble effect versions are of the same design as coal effect versions, but have a different surface finish.

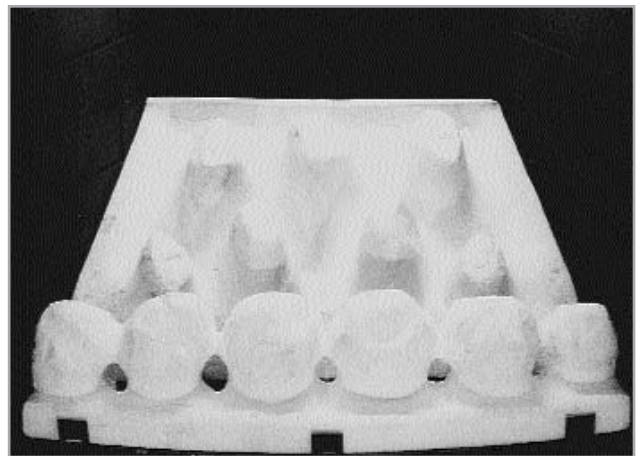

2. Open the bag of 16 ceramic pebbles. All of these pebbles are the same. Take five pebbles and place them as shown. Care should be taken to ensure that the pebbles bridge the gap between the front strip and the four supports at the front of the matrix. Care should also be taken not to push the pebbles right down between the supports, as this can affect the flame picture when the appliance is running.

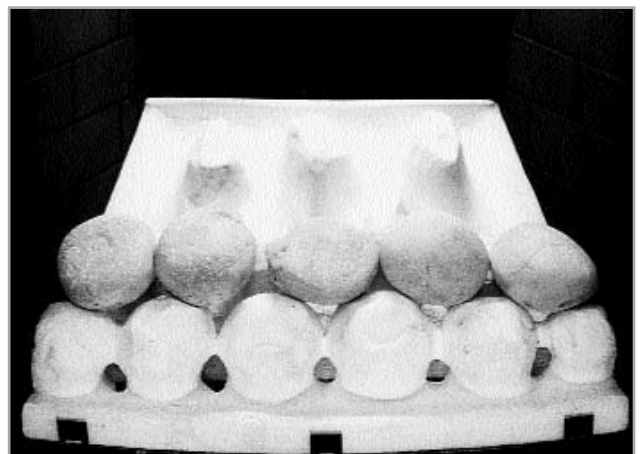

## 9.2 FUEL BED LAYOUT - continued Eko 3031 MODELS

### Pebble Effect Option

3. Take five more ceramic pebbles and position as shown to form the 'second row' of the fuel effect. The pebbles may be rotated as desired to fit into the gaps between the supports in order to create a random, realistic effect. Again, remember not to push the pebbles down too far into the valleys between the supports as this can have a detrimental effect to the flame picture.

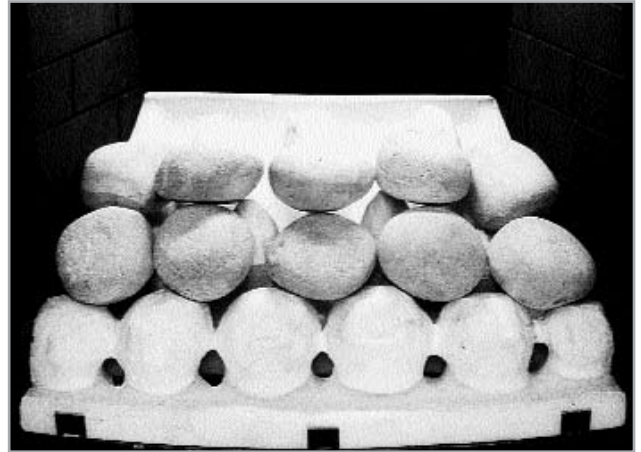

4. Now take another two pebbles and place behind the second row of coals, next to each other in the centre of the fuel bed. The pebbles may be orientated as desired to achieve a realistic effect. Keep the spacing between the pebbles even and uniform.

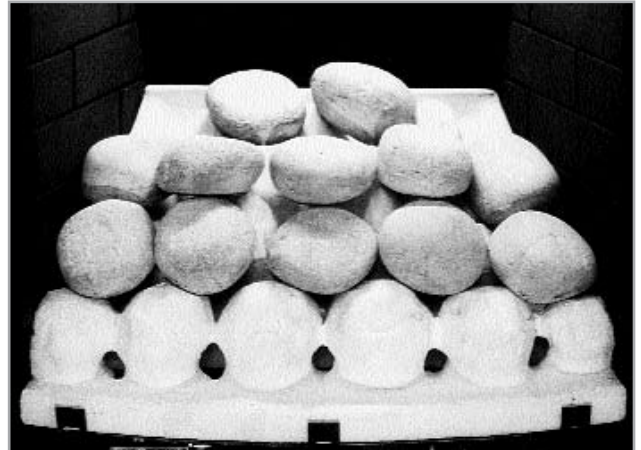

5. Finally, take the four remaining large pebbles and place at the back of the fuel matrix as shown. Once again, the pebbles may be orientated as desired in order to give a realistic effect. Avoid pushing the pebbles down between the supports. The fuel bed layout is now complete.

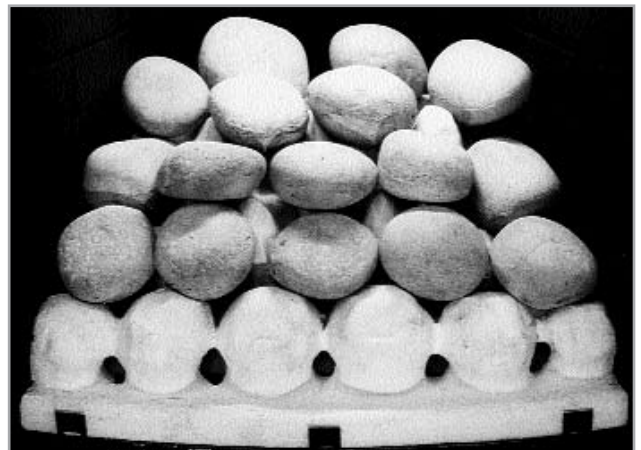

**The fire is designed to operate correctly with the pebbles supplied when assembled according to the instructions. Never add to the sixteen pebbles, or change them for a different type. Never throw rubbish or other matter onto the fuel bed.** Due to the light colour of the pebbles, some discolouration/sooting is to be expected during normal use.

## 9.3 FITTING THE DECORATIVE FRAME AND FRONT

The appliance is supplied with a decorative frame in a variety of finishes. The frame is held onto the firebox by one of two methods; either by magnetic pieces fitted to the steel backing plates, or as a three piece clip-on assembly. If not pre-fitted, the clip-on frame pieces should be hooked over the outer edges of the fireframe, and pushed firmly home. The sides should be fixed first, followed by the top bar, which overlaps the sides. Push firmly home. A plastic protective film may be applied to the outside of the frame and should be removed at this stage.

**IMPORTANT : Due to the possibility of sharp edges, care should be taken when handling the three-piece frame components. The use of protective gloves is recommended.**

Place the decorative firefront in front of the fire and slide the ashpan door into place. The firefront shown in these instructions may be different to the one supplied with the appliance.



## 10.0 TESTING AND COMMISSIONING

Turn on and test the gas supply up to the fire for any leaks, in accordance with the current edition of BS6891.

**WARNING : DO NOT USE AEROSOL TYPE LEAK DETECTOR AS THIS CAN DAMAGE THE ELECTRONICS.**

When the appliance is first used, protective oils coating the firebox may burn off. It is advisable to ventilate the room during this period, at least one hour.

## 11.1 OPERATING THE FIRE

Turn on the power supply and momentarily press the ON switch on the control box located to the right of the control knob. The fan should operate with the warning light illuminated. Almost immediately the fan will slow down to operating speed and a click may be heard as the safety solenoid opens allowing gas to the burner unit. The warning light on the control box should extinguish.

The pilot is visible through the left hand side of the fuel bed. Push in and turn the control knob to the SPARK position, and hold there for a few seconds.



Continue turning anti-clockwise through the spark click to the PILOT light position, ensuring the pilot has lit. If not, return the knob clockwise, and repeat.

When the pilot lights after the spark, keep the knob depressed for approximately ten seconds. Now release the knob and the pilot should stay alight. If not, retry ignition. If the pilot is extinguished during use of the fire, wait three minutes before repeating the ignition procedure.

To achieve the HIGH setting, push the control knob in slightly and continue turning anti-clockwise to the high position. The main burner should light after a few seconds. To decrease the setting to LOW, turn the control knob clockwise to the low setting. To turn to the PILOT position from the HIGH or LOW positions, press the control knob in, and return to the pilot position and release. To turn the fire OFF, keep the knob pressed in, return to the off position and release. Press the OFF button on the control box to switch off the fan.

## 11.2 SPARK FAILURE

The gap between the spark electrode and the pilot should be 3.5 - 4.5mm to produce a good spark. There should be no need to adjust this. If under any circumstances the electric spark fails, the pilot may be lit manually by proceeding with the ignition sequence as previously described, and after turning the control knob through the spark position, the knob should be held in and the pilot lit with a taper.

## 11.3 SETTING PRESSURE

Remove the screw from the pressure test point, situated on the main injector pipe by the pilot, and attach a U gauge. Light the fire on the HIGH setting. The setting pressure should be in accordance with the figures stated on page 2 of these instructions. The fire is factory set to achieve these pressures, and any significant variation could indicate a supply problem. If the pressure is too high, the gas supply meter may be set incorrectly. This should be checked with the fire running and if necessary reset by the gas supplier.

If the pressure is too low, then check the meter governor pressure with the appliance running. If this is incorrect it will need to be reset by the gas supplier. If the setting pressure is too low, but the meter pressure is acceptable, then a problem in the supply pipework is to be suspected. This will be dirt and debris, kinked or inadequate size pipes, restriction in a fitting or solder flashing across a joint.

**Note: you will not get an accurate reading of the inlet pressure with a pressure gauge on the end of the supply pipe - this is the static pressure in the system. You must use a T piece and measure the supply pressure with the fire on High - the dynamic pressure.**

## 11.4 SPILLAGE MONITORING SYSTEM

This fire is fitted with a flue spillage safety device (ODS). If the fire shuts down during use for no apparent reason then several things may be suspected. If a door or window has been opened creating a draught, then pilot disturbance is the problem, and removal of the draught should resolve this. If a grommet seal has been left out of the firebox then this also will also cause intermittent shutdown (recall your installer to fit). The gas pressure reaching the fire must also be checked (again, recall your installer to check and rectify any problem). The thermocouple connection into the back of the gas control valve may also have worked loose during installation, simply get the installer to tighten.

If pilot disturbance is not the cause, then the ODS safety system may be in operation. Switch the appliance OFF, check the flue for obstruction or leakage. Relight the fire and carry out a spillage test. DO NOT allow the appliance to be used if it continues to fail a spillage test. The aeration hole of the pilot must be carefully cleaned out on each annual service to ensure continued function of the ODS. The spillage monitoring system shall not be adjusted, modified, or put out of operation by the installer. Any spare parts fitted MUST be of a type supplied for the purpose by the appliance manufacturer. If the fire is not spilling, then further guidance should be sought, using the Troubleshooting section as a guide.

## 11.5 TESTING FOR SPILLAGE

Close all doors and windows to the room containing the appliance. Let the fire run on HIGH for five minutes. Take a smoke match, light it, and using a smoke match tube, hold it at the top edge of the fire opening, 25mm down and 25mm in. Starting 50mm in from either side, run the smoke match across the opening. All the smoke should be drawn into the upper firebox. Any smoke returning into the room indicates that spillage is occurring. If the initial test fails, run the fire for a further 10 minutes and repeat the test. When the test has been completed satisfactorily, repeat with any extractor fans in the premises running on the highest setting, and any communicating doors open. Finally, repeat with all doors open.

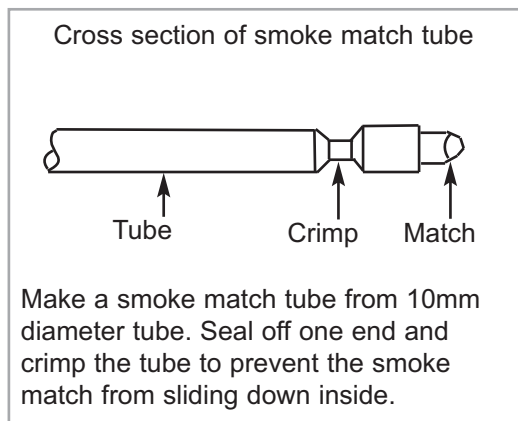

A. 25mm down from top of opening  
B. 25mm in from front of opening.  
C. Disregard outer 50mm either side of fireplace opening

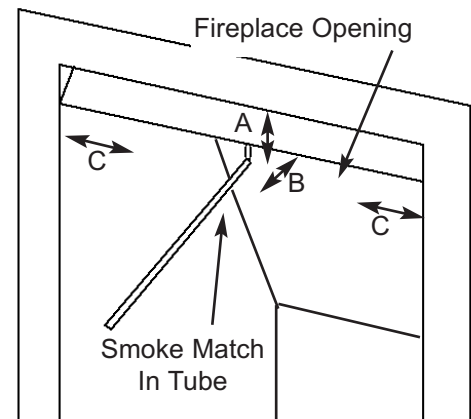

**NOTE: If spillage is still indicated after undertaking all of the above, there may be a problem with the flue and/or fan box setup, or insufficient ventilation is present.**

If the problem cannot be rectified immediately, then expert advice should be sought. Inform the user, disconnect the fire, and attach an explanatory label.

## 12.0 BRIEFING THE CUSTOMER

All instructions must be handed to the user for safekeeping. **Show the customer how to light and control the fire.**

After commissioning the appliance, the customer should be instructed on the safe use of the appliance and the need for regular servicing. Frequency of service depends on usage, but MUST be carried out at least once annually.

Scratched and other superficial damage to the matt black paintwork of the appliance can be covered with matching heatproof spray. Use only the manufacturers' recommended spray paint. Paint only when the fire is OFF and cold. Always mask off the surrounding area to prevent contamination with overspray. Ventilate the room during the use of the spray.

DO NOT attempt to spray paint the coals or ceramics, or wash them in water.

## 13.0 SERVICING

Isolate the fire from the gas supply. Ensure that the fire is fully cold before attempting service. A suggested procedure for servicing is detailed below.

1. Lay out the dust sheet and tools.
2. Disconnect electrical supply, and isolate gas supply.
3. Carefully remove the firefront, and ceramic components.
4. Remove the decorative frame, and check frame top for discolouration and signs of spillage.
5. Disconnect the gas supply pipe, and remove the two securing screws in the tray legs.
6. Disconnect the three way plug from the solenoid to the control box and remove the burner unit.
7. Strip off the burner pipes and clean thoroughly.
8. Clean out the injector and pilot assembly. DO NOT damage pilot injector.
9. Remove the two securing screws and lift away control box heatshield.
10. Check electrical connections to the control box are sound, and earth screw is fully tightened.
11. Re-assemble and re-fit the burner tray, making sure to reconnect the three-way plug.
12. Re-fit the decorative front.
13. Re fit and replace the ceramics, using genuine spares where necessary.
14. Turn on the gas supply, and leak test.
15. Dismantle the fan terminal unit and clean thoroughly, especially the sensing pipes and fan blades
16. Check the flue tube is free from obstruction and/or air leaks and sealing rings are correctly fitted.
17. Re-fit fan terminal, and reconnect the power supply
18. Check any purpose provided ventilation is un-obstructed
19. Check fan for operation and electrical soundness.
20. Switch ON the fire and test for spillage.
21. Check setting pressure and safe operation of the appliance.

For specific servicing instructions, see the relevant sections.

## 13.1 CLEANING THE CERAMICS

Remove the firefront and place to one side. Remove the ceramic components. Gently clean in the open air. Be careful not to create dust from the coals. Where necessary replace damaged components with genuine spares. Seal scrap components in plastic bags and dispose of at proper refuse sites as directed. Re-fit the coals carefully by referring to the relevant section of these instructions.

## 13.2 DISMANTLING THE BURNER TRAY

Remove the tray as previously described. The pilot unit can be removed by undoing the tubing nut, the thermocouple nut on the rear of the valve, HT lead, and the two securing screws, and lifting away. Remove the tubing nut from the valve end of the pilot pipe, and blow through to dislodge any debris. Clean the exterior of the pilot assembly with a soft brush and blow through the flame ports on the pilot head. Check the aeration holes are free from lint or dirt. The pilot assembly is a non-serviceable item, and should not be taken apart, other than the removal of the lint guard. The aeration hole must be absolutely clear internally for proper operation. A thoroughly cleaned (inside and out) oxypilot will cure a wide range of ignition faults. The injector can be removed from the rear of the assembly with two spanners to make cleaning easier. Remove the two tubing nuts on the ends of the gas pipe to the injector elbow. The injector pipe can now be checked for debris. Remove the nut retaining the injector elbow. Blow through the elbow to remove any debris.

The valve is not field serviceable, apart from the pilot filter. Remove the control knob by pulling it forwards, then remove the largest of the three screws on the face of the valve. Slide the filter out and clean away any debris that may have accumulated.

## 13.2 DISMANTLING THE BURNER TRAY - continued

The filter element should also be blown clean. This component should not require replacement, however if signs of deterioration are evident then a genuine spare must be used. If a large amount of debris is present in the filter then the pipework and control should be thoroughly cleaned before re-assembly.

## 13.3 CHECKING THE FAN ASSEMBLY

Disconnect the electrical supply, and remove the fan terminal cover. Check all components for signs of deterioration paying attention to the wiring, and ensuring all electrical connections are good.

Remove the terminal from the wall and check the flue tube is in the correct position. Check the flue is free from obstruction along its entire length. Clean outlet and airflow sensors with a suitable brush. Clean fan vanes and remove any debris. Ensure sealing rings are in position. Refit the terminal to the wall. Ensure that no plants etc. obscure the exhaust outlet.

Reconnect the electrical supply and check the operation of the fan. Press the ON switch, the fan should build up speed with the warning light illuminated and then rest at normal operating speed. The light on the control box should extinguish. The safety solenoid on the burner tray should now open. Establish a pilot flame but DO NOT light the main burner. Block the fan outlet with a piece of card. The fan should build up speed in an effort to clear the 'obstruction', when this fails the pilot will be extinguished and the fan cut out. When you are sure the operation is correct, refit the terminal cover and wire cage.

## 13.4 CONTROL BOX REMOVAL

Disconnect the electrical supply and isolate the gas supply. Remove the burner tray as previously described in the relevant section. Remove the two securing screws and lift away the control box heatshield. Slide the control box to the left off its mounting bracket, and remove the multi-way connector from the rear.

Replacement is reverse of removal, taking care to ensure the box is mounted securely and each individual connector pin makes good contact with the control box pin.

### Schematic of appliance wiring

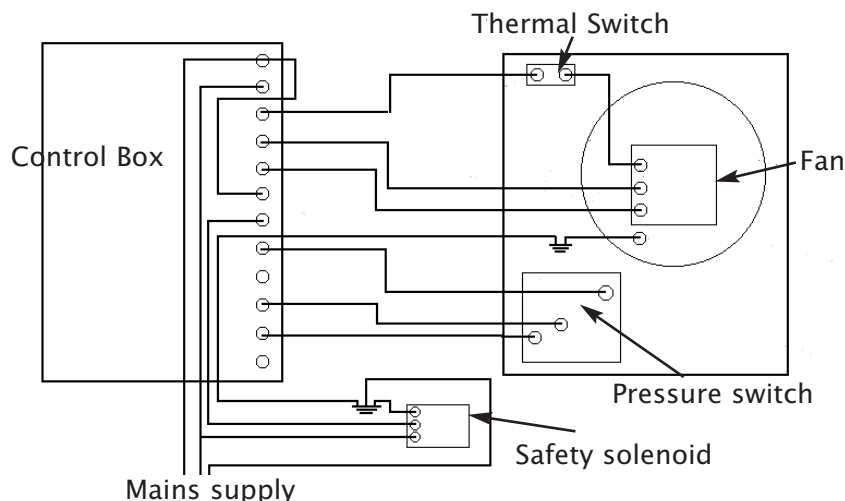

## 14.0 TROUBLESHOOTING GUIDE

<b>Fan fails to start</b>	<p>Check wall switch is turned ON</p> <p>Check the light on the control box illuminates when ON switch is pressed. If no light, check fuse.</p> <p>Turn OFF the wall switch, check all plugs and connectors from fire to fan and fully and correctly fitted. If all connections are correct, suspect faulty wiring loom or control box.</p>
<b>Fan runs but cycles from high to low.</b>	<p>Check fan outlet for obstruction</p> <p>Check all connections are fully and correctly fitted.</p> <p>Check pressure switch feed pipes are free from obstruction. Ensure silicone sensing pipes and properly fitted to sensing tubes. The terminal must only be fitted with the outlet facing downward. This appliance is only for use with 230V~50Hz, being the standard UK domestic supply.</p>
<b>Fan cycles high to low on windy days</b>	<p>This is quite normal on windy days</p> <p>If this occurs on still days then the pressure switch may be over sensitive. Consult the manufacturer before attempting any adjustment.</p> <p>In exposed areas a small deflector plate may be fitted to the terminal guard cage to reduce the effects of prevailing winds.</p>
<b>Fan runs in correct sequence but will not pass spillage tests.</b>	<p>Check test conforms to manufacturers instructions</p> <p>Check for blockages or leaks in flue or fan outlet.</p> <p>Check gas type and pressure are correct for appliance.</p> <p>Check for adequate ventilation or the effect of extractor fans.</p>
<b>Fan runs but pilot flame will not hold when control knob is released</b>	<p>Loose thermocouple connection in rear of gas valve</p> <p>Check pilot flame is engulfing tip of thermocouple.</p>
<b>Pilot will not light</b>	<p>Check gas is turned ON and all pipes are purged of air.</p> <p>Check for spark between pilot body and electrode.</p> <p>Check spark gap is correct to specification. Check the HT lead is connected to pilot body.</p> <p>Check gas line and filter for blockages.</p> <p>Check to see if pilot can be lit with match or taper whilst depressing control knob.</p> <p>Safety solenoid may not be opening. Listen for click after starting fan.</p>
<b>Pilot shrinks when fire is turned to high</b>	<p>Sign of insufficient gas pressure causing pilot starvation.</p> <p>Check appliance pressure at test point.</p> <p>Ensure restrictor elbow is fully open.</p> <p>Suspect undersized or partially blocked supply pipes.</p> <p>Check none of the fittings are causing restriction. Excess solder and flux can obstruct pipes.</p>
<b>Fan or fire cuts off when getting hot</b>	<p>Check for blockages in flue outlet which could cause thermal trip to operate.</p> <p>Check for pilot shrinkage due to low gas pressure.</p>
<b>Fan constantly runs at high speed.</b>	<p>Check connection from wiring loom to pressure switch are fitted securely.</p> <p>Check pressure switch feed pipes are free from obstruction. Under normal conditions the fan should only run for a few moments at high speed before the pressure switch detects airflow, dropping the fan down to normal speed. Consult the manufacturer before attempting any adjustment of the pressure switch</p>

# USER INSTRUCTIONS

Section	Contents	Page No.
1.0	Important Notes	1
2.0	Firefront	2
3.0	Clearances to Combustibles	2
4.0	Ventilation	2
5.0	Operating Instructions	2
6.0	Spillage Monitoring System	3
7.0	Cleaning	3
8.0	List of Spares	3

## 1.0 IMPORTANT NOTES

The installation of this fire **MUST** only be carried out by a competent<sup>[1]</sup> person in accordance with the Gas Safety (Installation and Use) Regulations 1998, the relevant British Standards, Codes of Practice, the Building Regulations and the manufacturers' instructions.

Failure to comply with the above recommendations could lead to prosecution and invalidate the appliance warranty.

Please ensure you are handed all of the manufacturers documents on completion of the installation. This will include these instructions.

Always keep a note of the installer's name and address, the original purchase receipt and the date of installation for future reference.

The appliance should be serviced regularly to ensure continued safe operation. See the servicing section for further details. Frequency of service will depend on use, but **MUST** be carried out at least once annually.

Parts of this appliance become naturally hot during use. It is recommended that a suitable fire guard conforming to BS 8423 : 2002 is used, especially where young children, the elderly, or infirm are concerned.

Combustible items, such as flooring and furniture, and soft wall coverings (such as flock, blown vinyl or embossed paper) may discolour if fitted too close to the fire. See relevant section for further details on clearances to combustibles. No combustible material or flooring should protrude onto the hearth.

**DO NOT** burn any foreign material on this fire, the coals must be of the correct type and laid out in accordance with the relevant section of these instructions. Failure to do so could create a hazard or lead to sooting.

This appliance is fitted with a flue blockage safety device which will shut down the fire if abnormal flue conditions occur. It is **NOT** a substitute for an independently mounted Carbon Monoxide detector.

The fire is only suitable for use with the gas type for which it is supplied.

[1] GB - Gas Safe™ registered operatives (Northern Ireland only- CORGI registered operatives) are the only class of person considered as competent by the HSE under the Gas Safety (Installation and Use) Regulations 1998.

## 2.0 FIREFRONT

This fire is supplied with a particular style of firefront. Use of the firefront will ensure an adequate airflow under the firebed for the correct functioning of this appliance.

Compliance with safety standards cannot be guaranteed if another style of front is used.

## 3.0 CLEARANCES TO COMBUSTIBLES

A combustible shelf may be fixed to the wall above the fire, providing that it complies with the dimensions given below.

Maximum depth of shelf	Minimum distance from finished hearth surface to underside of shelf
100mm (4in)	745mm (29 1/4 in)
150mm (6in)	845mm (33 1/4 in)
203mm (8in)	895mm (35 1/4 in)

A non-combustible shelf may be fitted to within 10mm of the top edge of the fireframe. Combustible materials, such as wood, may be fitted to within 100mm (4in) of either side of the frame of the appliance, providing the forward projection does not exceed 100mm (4in). Any combustible side walls must be at least 500mm to the side of the radiant heat source. As with all heating appliances, any decorations, soft furnishings, and wall coverings (i.e. flock, blown vinyl and embossed paper) positioned too close to the appliance may discolour or scorch.

## 4.0 VENTILATION

**No purpose provided ventilation is normally required for this appliance.** The requirements of other appliances operating in the same space or room, and the results of a spillage test must be taken into consideration when assessing ventilation requirements, this will have been carried out by your CORGI registered installer.

For Republic of Ireland, ventilation may be required, see IS 813, ICP3, IS 327, and any other rules in force.

## 5.0 OPERATING INSTRUCTIONS

Turn on the power supply and momentarily press the ON switch on the control box. The fan should operate with the warning light illuminated. After a very short time the fan will run at normal speed and a click may be heard as the safety solenoid opens. The warning light should extinguish.

The pilot is visible through the underside of the left hand front coal strip. Push in and turn the control knob to the SPARK position, and hold there for a few seconds. Continue turning anti-clockwise through the spark click to the PILOT light position, ensuring the pilot has lit. If not, return the knob clockwise, and repeat.

When the pilot lights after the spark, keep the knob depressed for approximately ten seconds. Now release the knob and the pilot should stay alight. If not, repeat ignition. If the pilot is extinguished **during use**, wait three minutes before repeating the ignition procedure. To achieve the HIGH setting, push the control knob in slightly and continue turning anti-clockwise to the high position. The main burner should light after a few seconds. To decrease the setting to LOW, turn the control knob clockwise to the low setting. To turn to the PILOT position from the HIGH or LOW positions, press the control knob in, and return to the pilot position and release.



To turn the fire OFF, keep the knob pressed in, return to the off position and release. Press the OFF button on the control box to switch off the fan.

## 6.0 FLUE SPILLAGE MONITORING SYSTEM

This fire is fitted with a flue spillage safety device (ODS). If the fire shuts down during use for no apparent reason then several reasons may be suspected. If a door or window has been opened creating a draught, then pilot disturbance could be the problem, and removal of the draught should resolve this. The fire can then be re-lit in accordance with the previous section. A sealing grommet may have been omitted when the fire was installed, and the original installer should be called to check this, the gas pressure and pipework.

If pilot disturbance is not the cause, then the ODS safety system may be in operation. Switch the appliance OFF, call in your installer to check any ventilation and carry out any remedial work required. DO NOT allow the appliance to be used until the installation is passed as safe.

## 7.0 CLEANING

Before carrying out any of the following operations, ensure that the fire is OFF and completely cold.

**FIREFRAME** - This is retained by one of two methods, either by magnetic backing pieces, or a three piece clip-on assembly. The magnetic frame may be removed for cleaning if required, however the clip-on style must not be removed. A wipe with a dry cloth is normally sufficient, but on stains it is permissible to use a damp cloth with a mild household cleaner, followed by a wipe with a dry cloth. DO NOT use abrasive cleaners as these may damage the finish. To re-assemble ensure the magnets are placed on the steel backing pieces, and re-fit to the firebox.

**IMPORTANT : Due to the possibility of sharp edges, care should be taken when cleaning the three-piece frame components. The use of protective gloves is recommended.**

**FIREFRONT** - Any dust accumulating in the firefront may be removed using a vacuum cleaner or dry cloth. Heavy stains may be removed by using a damp cloth and mild household detergent. Brass parts of the firefront may be cleaned using a suitable brass cleaner. Replace the front centrally against the fire after cleaning.

**PAINTED AREAS** - These can be cleaned using a dry cloth.

**COALS AND CERAMICS** - See the relevant section in the Installation Guide of these instructions. Do not create dust from the coals. Clean gently in the open air. Replace components with original spares only as necessary.

## 8.0 LIST OF SPARES

PART NO.	ITEM
F780059	Pack of 11 coals (Eko 3021 models)
F780034	Fuel matrix (Eko 3021 models)
F550038	Pack of 16 coals (Eko 3031 models)
F550050	Pack of 16 ceramic pebbles (Eko 3031 models)
F780007	Fuel Matrix (Eko 3031 coal version)
F780016	Fuel Matrix (Eko 3031 pebble version)
F780008	Front ceramic strip (Eko 3031 coal version)
F780017	Front ceramic strip (Eko 3031 pebble version)
F730006	Pilot unit
Please Enquire	Decorative Frame
Please Enquire	Decorative Front